

ALTERNATIVE BASE FIXING FOR CONCRETE FLOORS

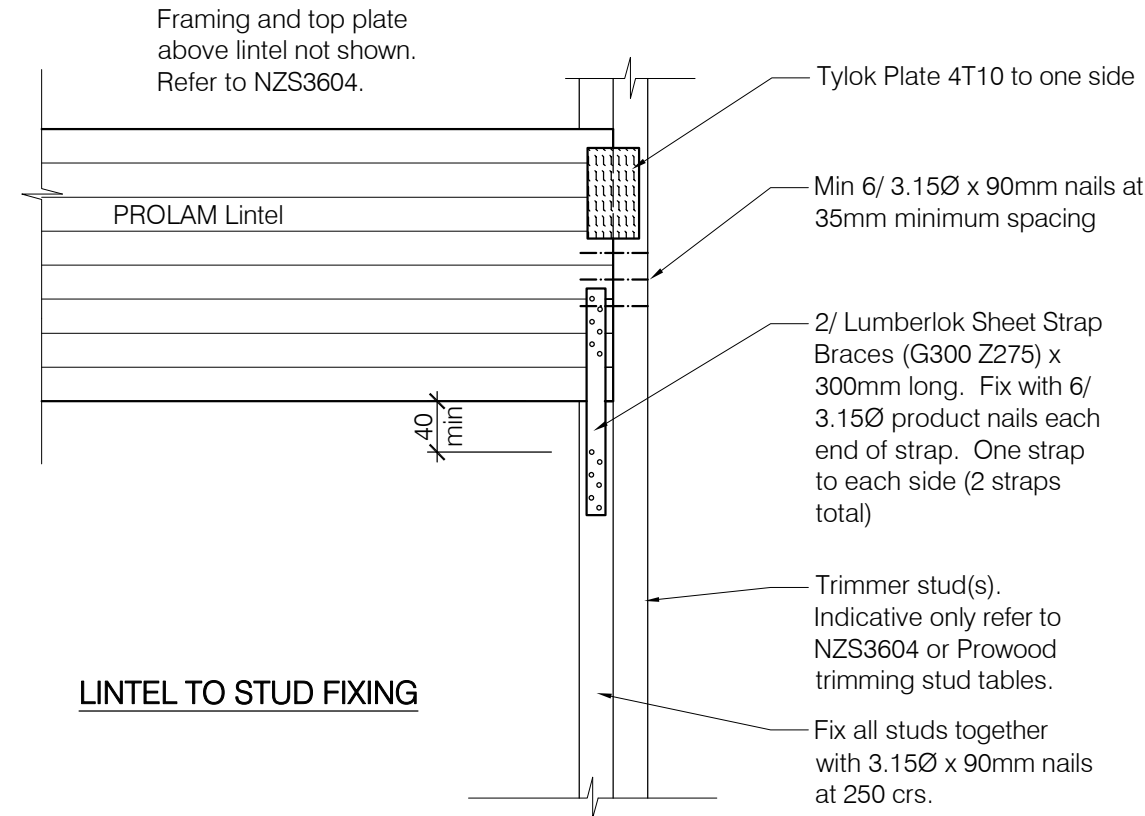

LINTEL TO STUD FIXING

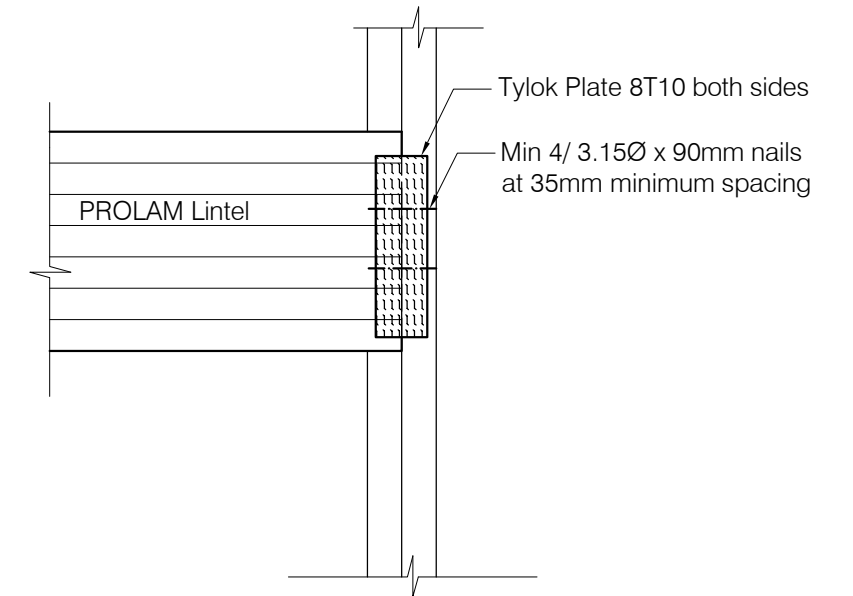

LINTEL TO STUD FIXING ALTERNATIVE

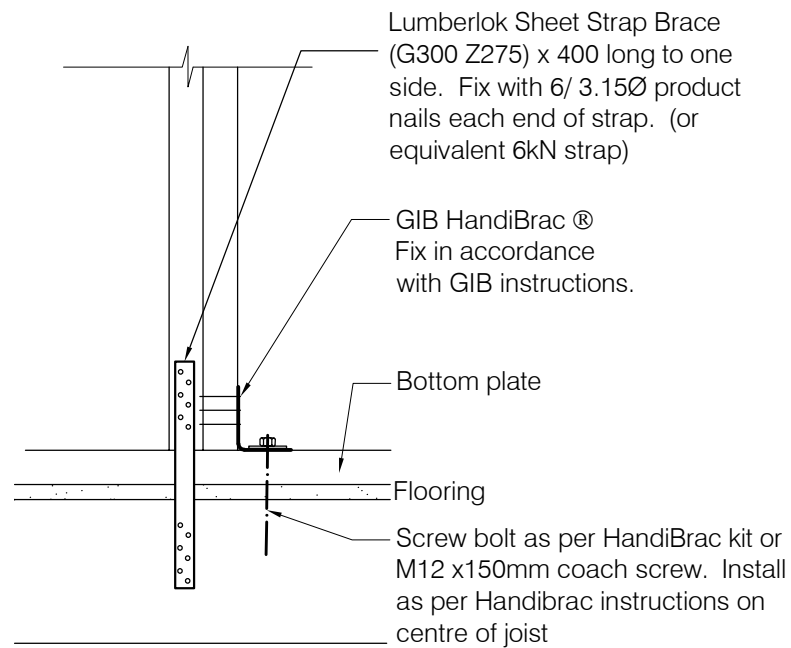

ALTERNATIVE BASE FIXING FOR TIMBER FLOORS

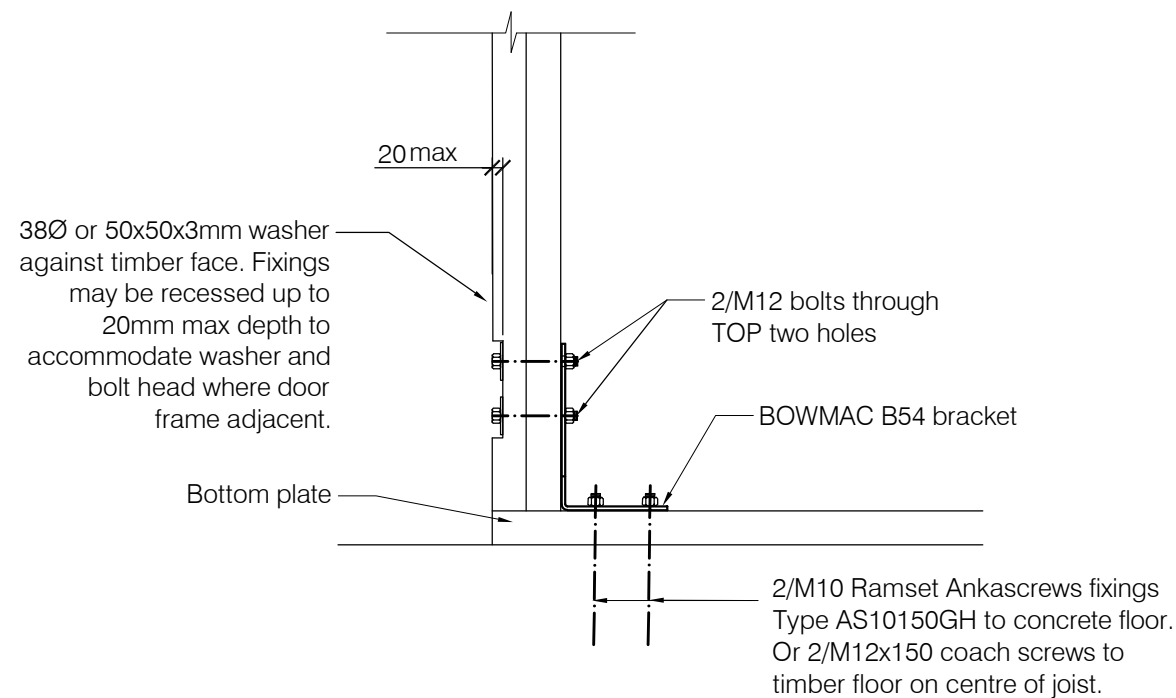

BASE FIXING FOR FRAMING TO ONE SIDE (eg at door frame)

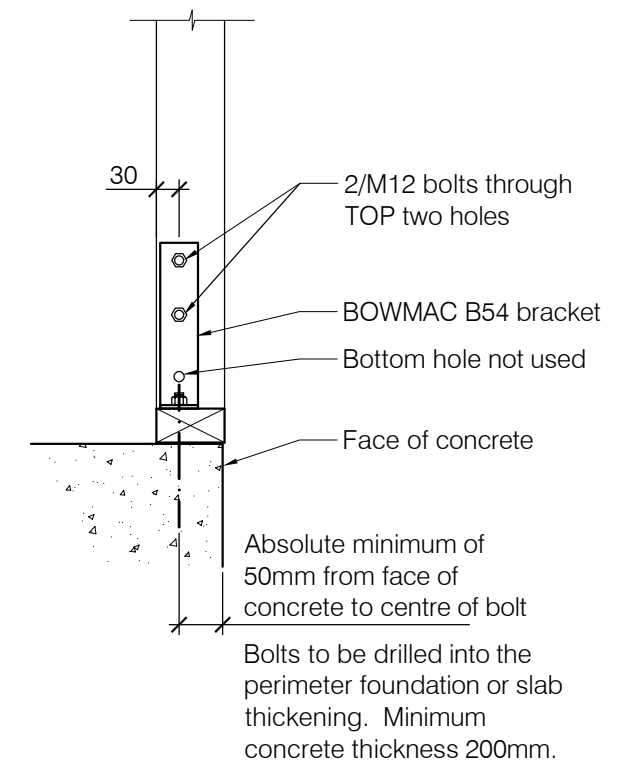

CONCRETE FLOOR